

Reinhold Environmental Ltd.



2006 APC Round Table & Expo Presentation

July 16-18, 2006, Columbus, OH

All presentations posted on this website are copyrighted by Reinhold Environmental, Ltd (RE). Any unauthorized downloading, attempts to modify or to incorporate into other presentations, link to other websites, or obtain copies for any other uses than the training of attendees to RE's Conferences is expressly prohibited, unless approved in writing by RE or the original presenter. RE does not assume any liability for the accuracy or contents of any materials contained in this library which were presented and/or created by persons who were not employees of RE.

TRANSFORMER/RECTIFIERS

FOR

ELECTRO-STATIC PRECIPITATION

Presentation by
Hank Del Gatto

EPSCO INTERNATIONAL

CONVENTIONAL TR POWER SUPPLY THREE (3) MAJOR COMPONENTS

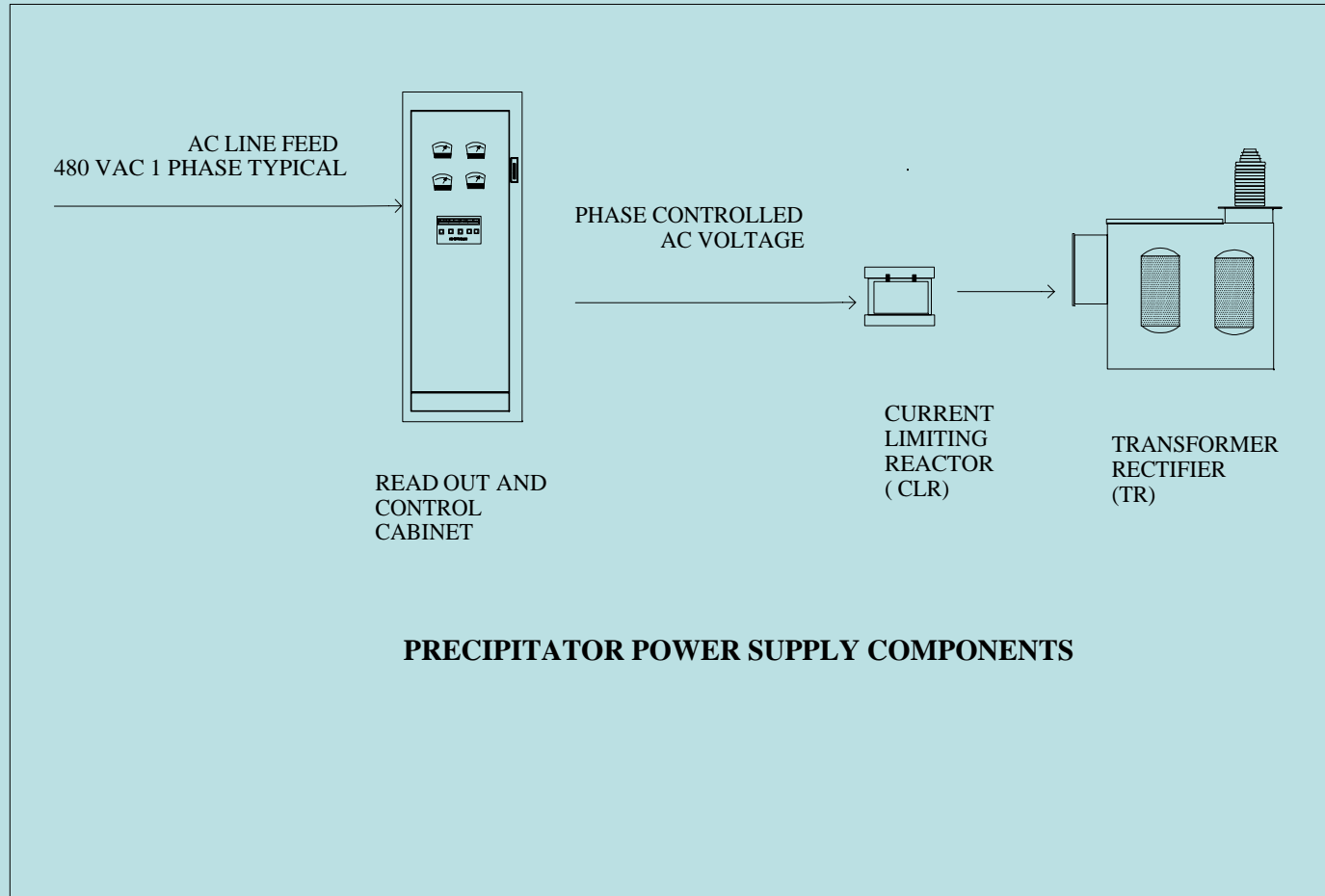

CONTROL CABINET

The Control Cabinet provides a User interface as well as a housing for the control and monitoring of the ESP Power System.

Included in a typical system are :

- Analog Meters for quick visual indication of operating level.
- Electronic Controller for Controlling power (KV and mA) delivered to the TR
- SCR Module with Heat Sinks under control of the Electronic Controller for Phase Control of the AC Feed to the TR.
- Circuit Breaker, Contactor and Misc. control and interlock relays
- Optional Current Limiting Reactor (CLR)

Current Limiting Reactor (CLR):

The CLR serves two purposes in the ESP Power Supply.

1. As the name suggests the primary purpose is to limit the surge current that can be delivered to the ESP as a result of sparks and Arcs that will occur. The value of the CLR is expressed as Inductance in Milli-Henris or Percent Impedance. The typical CLR value is selected such to limit the current surge, within a 8.3 msec (Line $\frac{1}{2}$ Cycle) to approximately 2 – 4 limitation is required because the SCR controller cannot respond (turn off) until the end of the line cycle.
2. The secondary purposed of the CLR is provide a means for decreasing mA and KV ripple on the DC Power delivered to the ESP. The reduced Ripple results in increased average KV levels, and increased ESP performance (efficiency)

TRANSFORMER RECTIFIER (T/R) SET

The Transformer Rectifier (TR) converts the phase controlled AC power feed from the SCR Controller to a High Voltage DC Power Source for the Electrostatic Precipitator (ESP)

Output for industrial ESP's is Negative (-) Voltage with respect to Earth Ground.

Voltages from -20,000 Volts (-20 KV) to Voltage greater than -75,000 Volts (-75 KV) are typically used.

The magnitude of the Voltage is a function of the distance between the Collecting Plate or Surface and the Electrodes. Spacing from 3 inches to 6 inches (wire to plate) are common. This is $\frac{1}{2}$ the 'Plate Spacing'

ESP current from a few milli-amps (mA) up to over 2,000 mA may be employed. The ESP current is a function of the amount of surface area of the field and the properties of the gas flow.



Double Half Wave

Splitter Switch

Ground Switch

1000ma

800ma

Reactor

Round TR's- Stock/Solvera Corp



Single Bushing TR

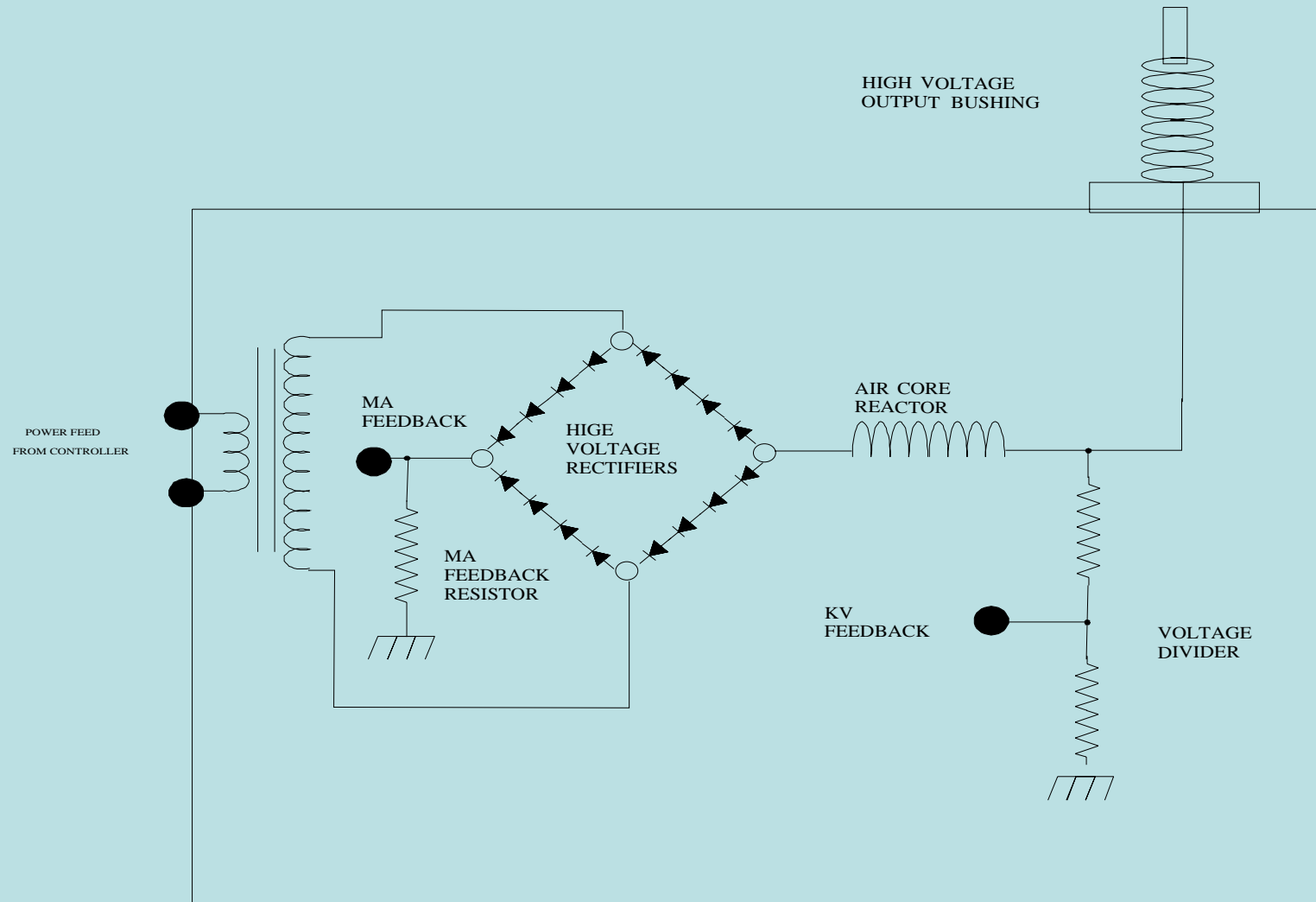

TRANSFORMER RECTIFIER ELECTRICAL COMPONENTS

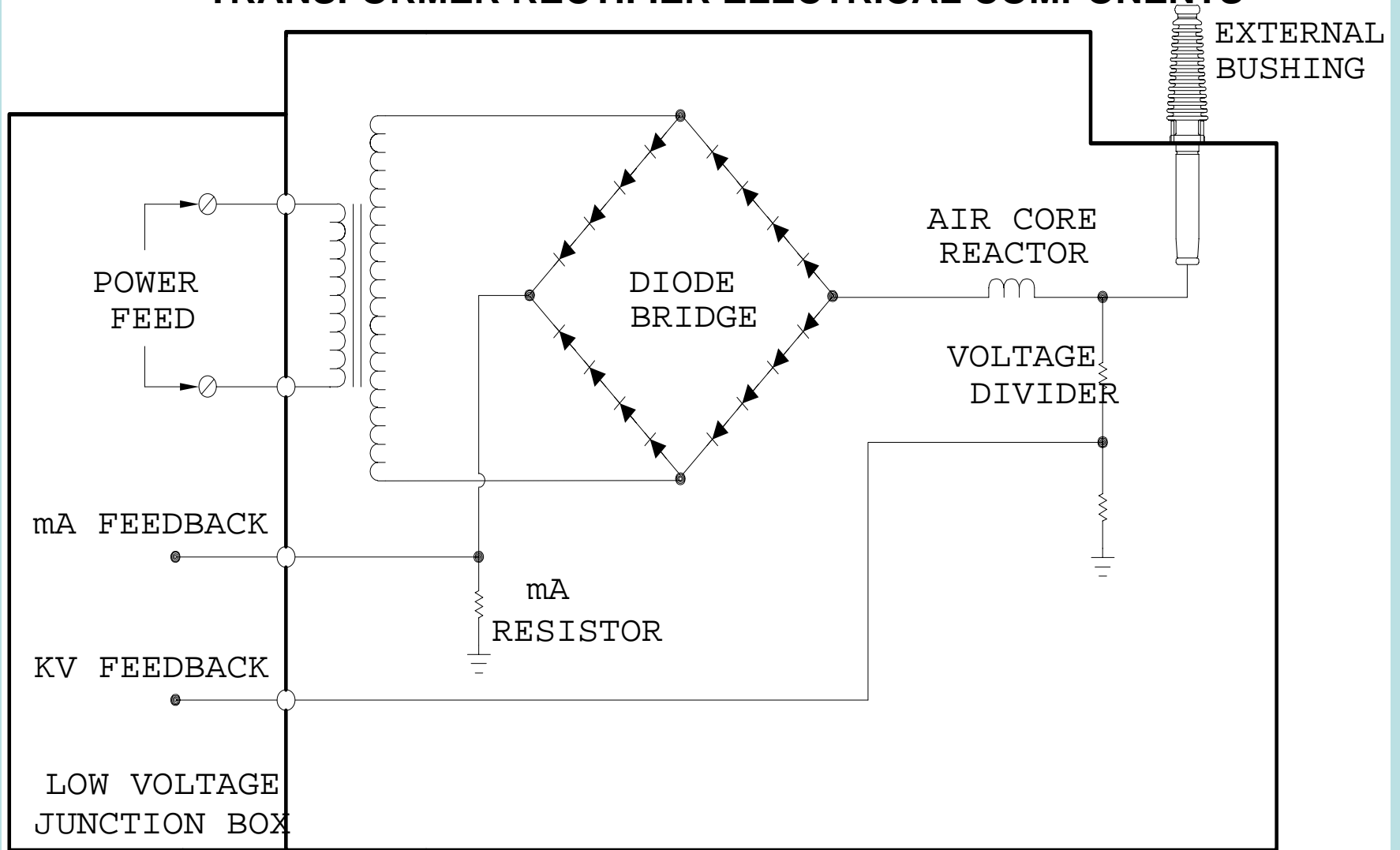

- Courtesy of NWL

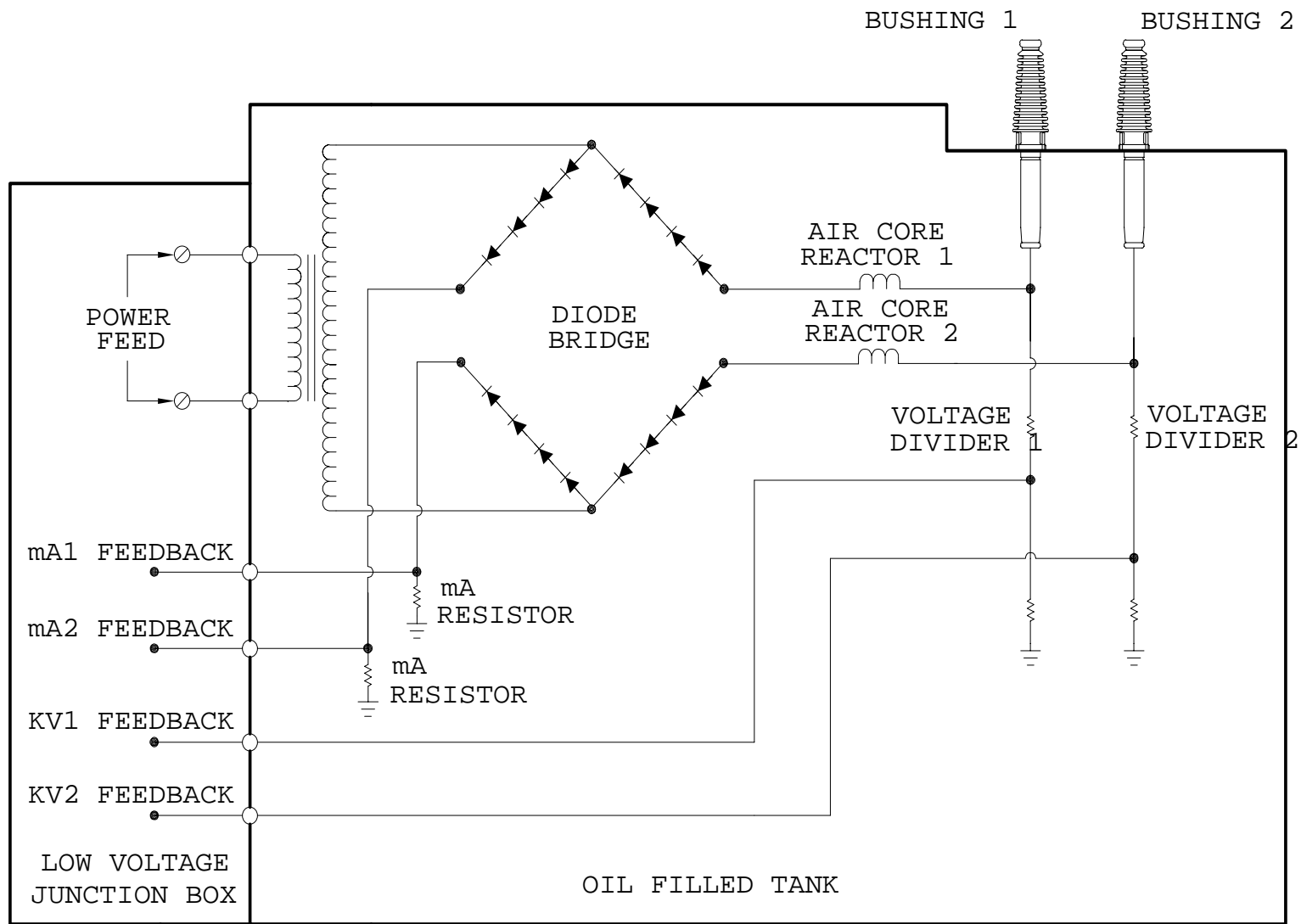

Double Half Wave T/R Set (courtesy of NWL)

Stock Inc. TR Internals, ACR and HV Divider HV Rectifier Assemblies (Blue)

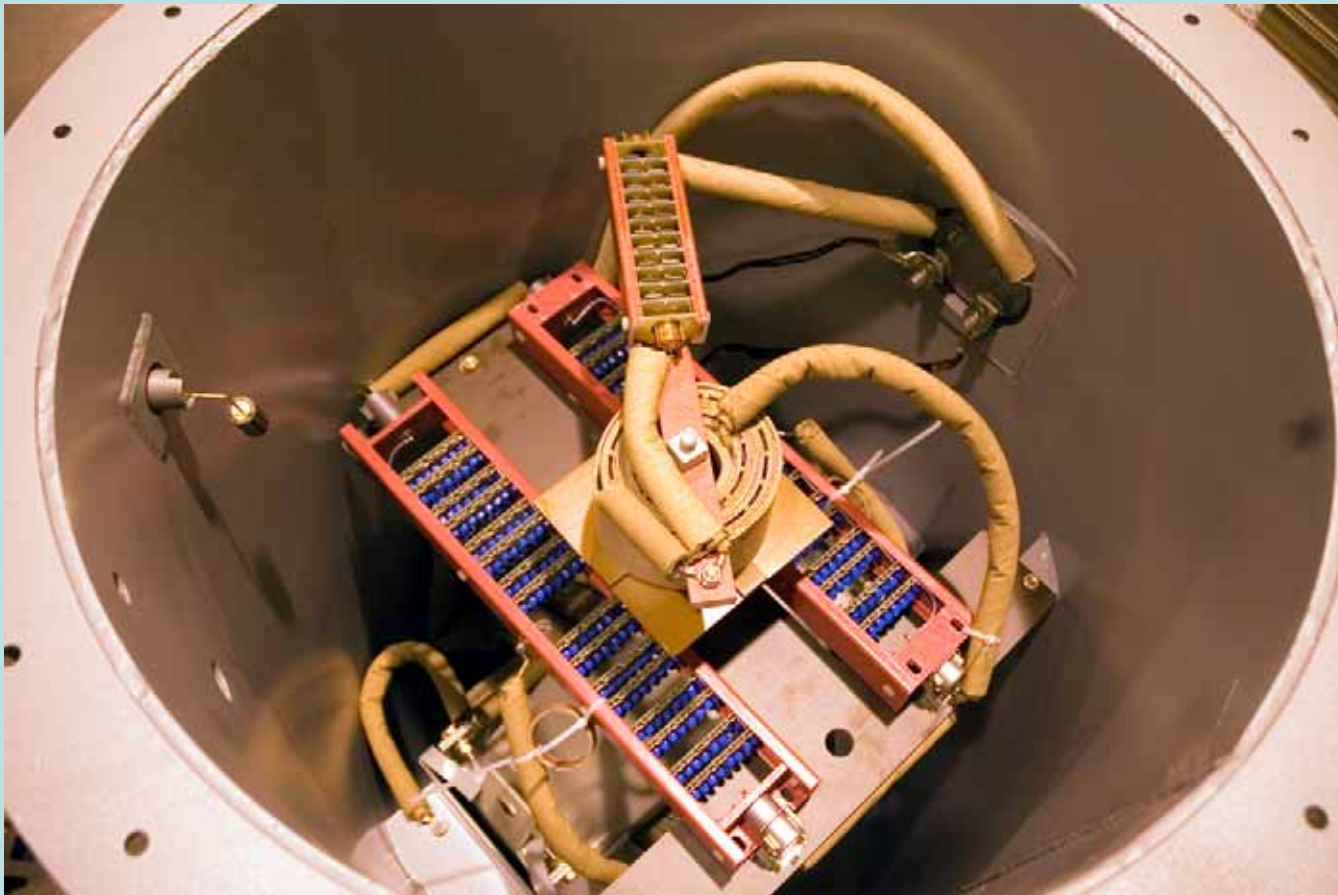

TR Internals, HV Divider, ACR and Diodes (Stock Inc. Photo)

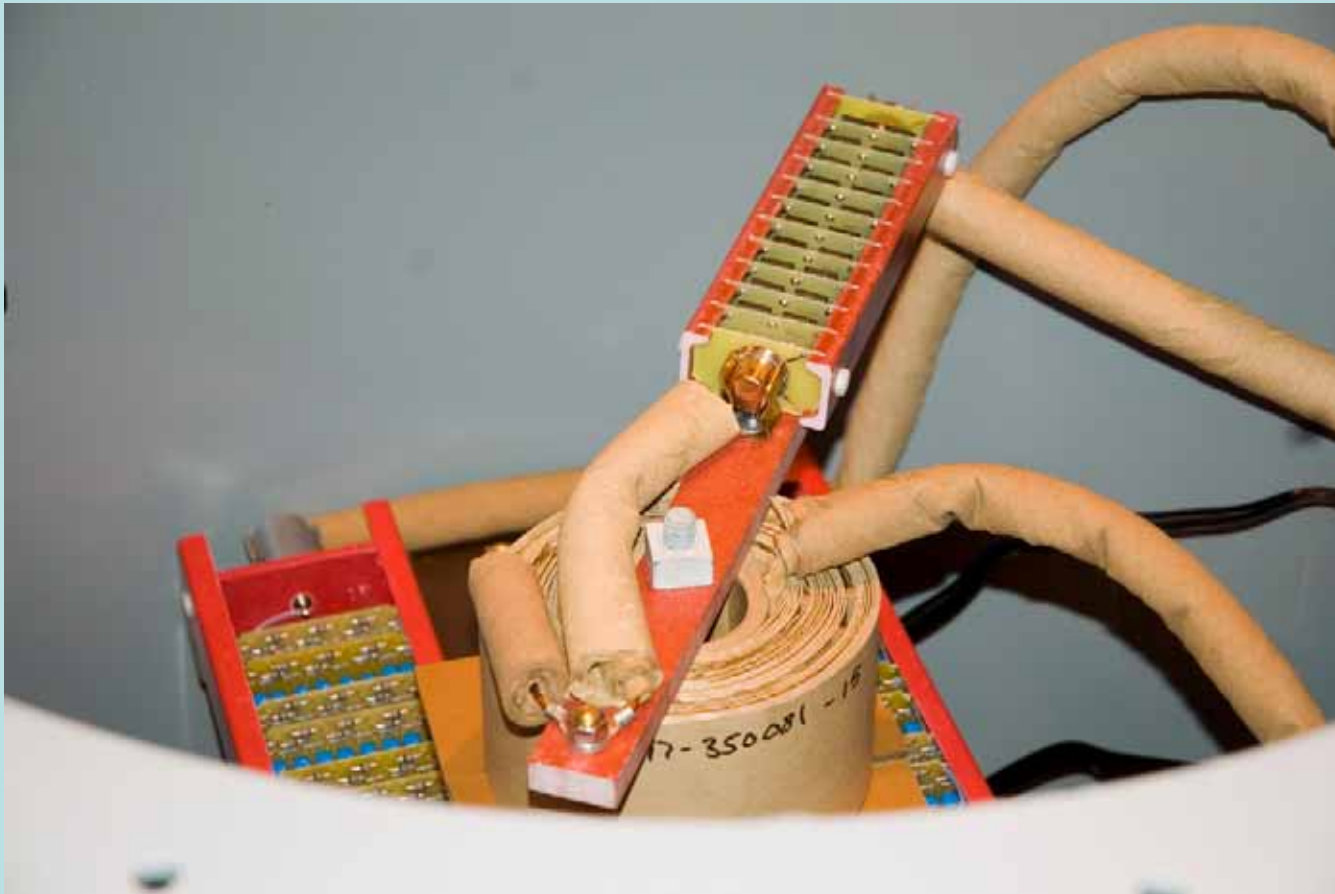

TR SIZING, KV and mA

- TR's are rated primarily by the required Voltage (KV) and Current (mA) output required. The multiplication of these two parameters determines the KVA or Power Rating of the TR.
- The rating requirement is a function of the field characteristics together with the gas/particulate properties.
- Proper sizing of a TR will result in operation between 120 and 160 degrees (of 180 deg) conduction angle.
- Over rating of Current capability (mA) is not in itself a problem providing that the CLR can be properly adjusted to obtain proper conduction angle.

TR SIZING, KV and mA (pg2)

- Over rating of the output voltage (KV) can have serious implications in that the control will be limited to reduced conduction angle and high ripple, high sparking field.
- Often times the same TR is used on inlet to outlet field even though the operating levels are quite different.
- To some degree TR mismatch can be compensated for through the use of high inductance CLR.
- Severe mismatch can be corrected by the addition of a step down auto transformer to reduce the AC feed voltage to the TR

TR Component : Transformer

- The transformer accepts a phase controlled AC feed of 0 to 480 VAC and steps this up to the required KV output level.
- The 'Turns Ratio' is the ratio of input to output voltage and current.
- A 'Turns Ratio' of 100:1 steps up 400 volts to 40,000 volts (40 KV) while the current steps down from 100 Amps to 1 Amp (1000 mA).
- The 'Form Factor' is the ratio of AC RMS value and DC Value. Form Factor Of 1.2 is typical that is that 40,000 Volts Ac will yield 33,000 Volts DC (33 KV).

TR Component : Transformer Windings

- The TR can use either Copper or Aluminum windings. Both materials yield acceptable performance when used correctly.
- Primary windings can either use round or rectangular conductor or foil (Sheet stock).
- Kraft paper is typically used for layer insulation for both primary and secondary. The insulating material breakdown is the determining factor in Transformer life span.
- Foil winding of secondary's is rarely used because of costs yet do yield high reliability.

TR Primary Winding using Rectangular Copper Conductor (Stock Inc.)

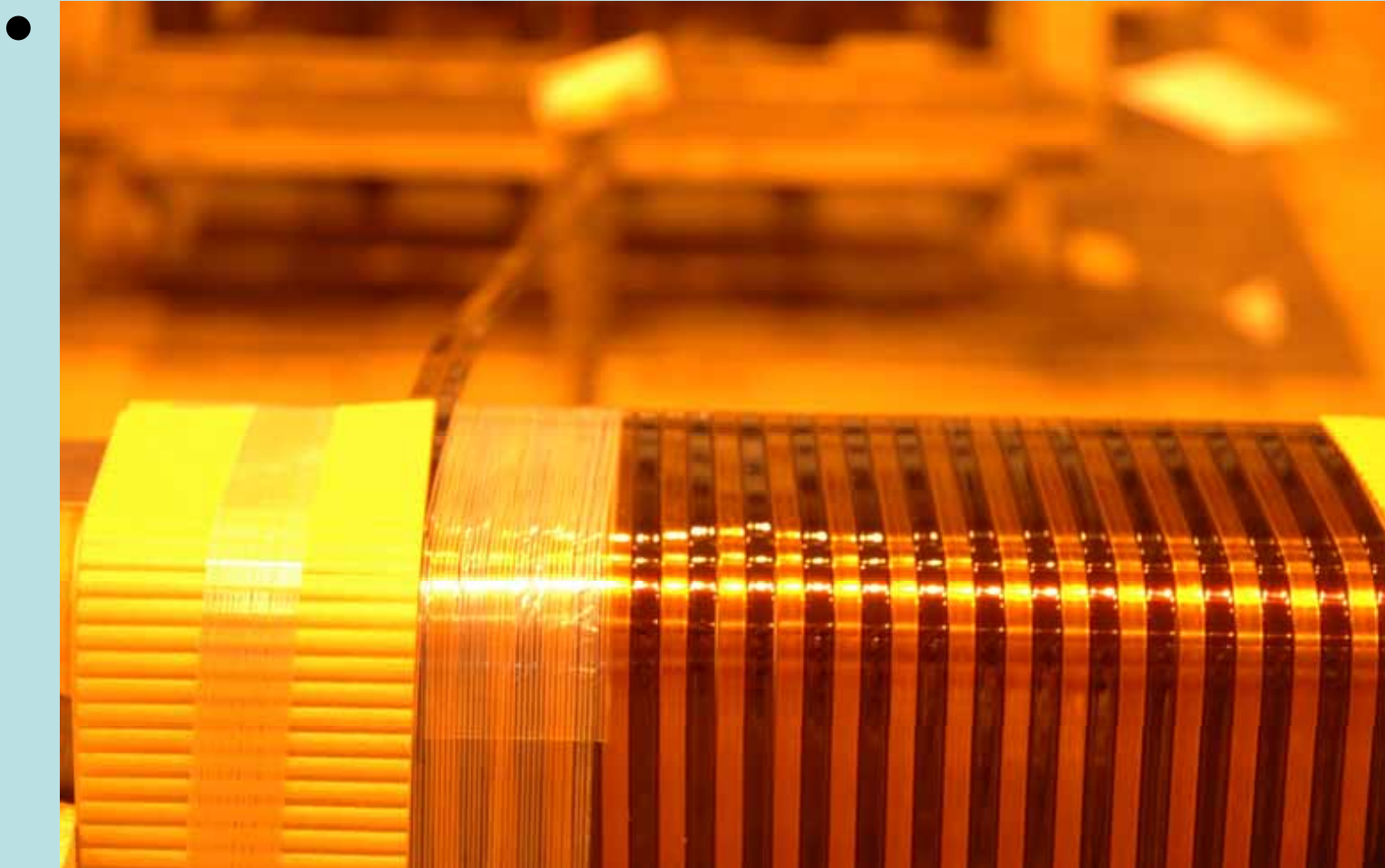

TR Secondary Winding, Copper wire, Notice 'Margin Filler' Strip (Stock Inc)

-



TR Component: Rectifier Bridge

- Full wave Bridge is currently configuration of choice, Older TR's using split Bridge with two bushing are rarely used.
- Rectifier bridge should be rated for twice (2X) peak output voltage of TR and 2 to 4 times current rating.
- Both Avalanche diodes and RC Compensated Diodes are currently used to distribute reverse voltage.
- Modular construction of Bridge assembly permits field repair; some times accessible thru top TR cover.
- Rectifier Bridge relies upon proper operation of Controller, CLR and ACR for survival.

TR Component: Air Core Reactor (ACR)

- The ACR is an electric coil that is located under oil in the TR tank.
- The purpose of the ACR is to protect the TR Rectifier Bridge from high frequency, high voltage spikes and disturbances that occur within the sparking ESP.
- The ACR is typically a coil of less than 12" x 12"
- The ACR is electrically connected between the Bridge and the HV Bushing and must be capable of withstanding up to 2 times peak rated voltage.
- When sparking occurs the total ESP voltage is impressed on the ACR.

Air Core Reactor, notice Insulation and Window to allow cooling and Dielectric (Stock Inc.)



TR Component: Bushings

- Bushings are the means for electrical connections to the TR internal components in oil.
- The low voltage bushing connections may be connected below the oil level or through the tank top above the oil level.
- The High Voltage must be below the tank oil level
- High Voltage bushings are typically ceramic, however Epoxy type bushing can be effectively used. The inside of the HV bushing is often oil filled and may be top or side mounted.
- Oil leaks through bushings can be a difficult problem

TR Component: MA Feed Back Signal

- This signal is used for Control and monitoring.
- The ma Feed back is implemented by a power resistor that is mounted in the Low Voltage Junction Box. Resistance of approximately 10 Ohms is used to provide a 10 Volt DC signal that will correspond to a 1000 ma TR output. Other resistor values may be used for other ratios. The ma feed back is electrically connected between the Positive (+) leg of the HV Bridge and Earth Ground.
- The Resistor must be of High Reliability Rating and also backed up by a protective HV Device.
- ***If this component fails the rated High Voltage is imposed upon this feed back wire.***

TR Component: KV Feed Back

- This signal is used for Monitoring and Control
- The KV signal is implemented through use of a high voltage divider with a typical ratio 8,000 to 1.
- The ratio uses an 80 Meg Ohm resistor on the high end and a 10K Ohm resistor on the low end, thus producing a feedback of 8 KV per volt. 120 Meg dividers are sometimes used for higher voltage TR's
- The high Resistors are mounted inside the tank under the transformer oil, while the low end resistor is located in the Low Voltage Junction Box.

TR Component: KV Feed Back (pg2)

- The type of resistor used varies by manufacturer. Properly sized Metal film, Ceramic Composition as well as other technologies may be used.
- The ceramic Composition resistors provide excellent stability over load conditions and are inherently non-inductive.
- Metal film resistors of 'non-inductive' high voltage design are commonly used with excellent reliability.
- Typical KV Feed Back systems are not frequency compensated, yet provide a reasonable representation of the ESP signal.
- ***Like the ma Feed Back.. This signal must be protected since the full output voltage of the TR can be imposed on this wire***

TR Component: Dielectric Fluid

- The Dielectric Fluid is used to provide cooling for the TR internal components as well as to provide high voltage insulation.
- Mineral Oil, Silicone Oil and R-Temp Oil are fluids used.
- Mineral Oil is the most common type used and is generally referred to as “Transformer Oil”
- Silicon Fluid or R-Temp type fluids are used when fire is of greater concern.
- Prior to 1970 PCB fluid (Askeral) was permitted for use in high flammability applications. Most of these transformers have since been scrapped or re-filled with safer fluids.

Dielectric Fluid Testing & Maintenance

- The frequency for sampling and testing of TR fluid for preventative maintenance purposes is dependent upon the severity of use as well as the criticality of operation. Yearly sampling is often recommended.
- The breakdown of the fluid and/or the detection of water or other contaminants can often allow corrective action before a complete failure occurs.
- Water contamination can be caused by the normal 'breathing' of the TR as temperature changes occur. Water in the fluid is measured in part per million. Mineral oil saturation point is approx 70 ppm while silicone can be as high as 200 ppm.

Dielectric Fluid Testing & Maintenance (pg2)

- As Silicone fluid has a greater affinity for water absorption it also maintains a higher dielectric properties than Mineral oil at high water concentrations.
- It should be noted that the affinity for the moisture to concentrate within the transformer insulation is much greater than that of the oil. Estimate that up to 90% of the water in the transformer will be absorbed by the insulation. The filtration of oil to remove water must be repeated to migrate water from the solid insulating papers and materials.
- The presence of dissolved gasses or particles in the fluid indicates internal arcing and/or insulation breakdown.

TR Component: Tank Enclosure

- The TR is contained within a sealed steel tank that is either Stainless Steel or Painted Carbon Steel.
- Many of the Round or Cylindrical tanks are made to support a full vacuum.
- Rectangular tanks cannot usually support full vacuum and are processed (de-watered and 'oiled') by putting the entire assembly into a heated vacuum chamber.
- Tanks capable of full vacuum can be so processed in the field if necessary for field servicing.
- Most TR's have removable top covers to allow access to the internal components

TR Component: Tank Enclosure (pg2)

- Some configurations use the TR top cover to mount the components including the transformer. Such configurations have all connection on the top so that the entire 'guts' can be lifted for access.
- Side mount Boxes for low voltage connections of the power feed and the feed back signals are most common.
- The Low Voltage Junction Box may also be used to house the CLR and Transformer Tap selection.
- The High Voltage Bushing can be specified for top or side mounting

TR tank Component: External Radiators

- External Radiators are often used on TR's to allow for a smaller footprint as well as a smaller volume tank
- Modern TR's must be capable of reliable performance in the often Hot ambient of a ESP structure
- Since fans are not used the TR relies upon the surface area of the tank walls to radiate internal heat losses.
- The additional expense of such radiators is typically offset by reduction in Tank volume and as such dielectric fluid. Especially so when Silicone or R-Temp fluids are used

Typical TR Radiator (Stock Inc.)

-



THANK YOU